

HIGHLIGHTS

- Input isolator enables long distance transport with minimal signal degradation
- Convenient 1-RU form factor
- Embedded SNMP agent (v1, v2c, v3)
- Support of SCTE HMC MIBs
- Embedded Web (HTTP) server for user-friendly graphical interface

The Harmonic MAXLink™ transmission system is a family of transmitters and optical amplifiers designed for 1550 nm-based network applications. The MAXLink system provides a cost-effective solution for a variety of applications and architectures, including long haul applications that are beyond the reach of 1310 nm transmitters and fiber dense architectures which take advantage of high power optical amplifiers. In addition, this system is ideally suited for new, evolving transport architectures such as redundant rings, broadcast layer transmission, and hub interconnects used in broadband networks.

The MAXLink product line consists of 1-RU rack mount modules for 19" racks, including the HLT series of broadcast optical transmitters as well as a full range of optical amplifiers. The transmission system has been designed to complement Harmonic's PWRLink™ 1310 nm DFB transmitter family.

Full monitoring and configuration are available through the embedded SNMP agent and HTTP server.

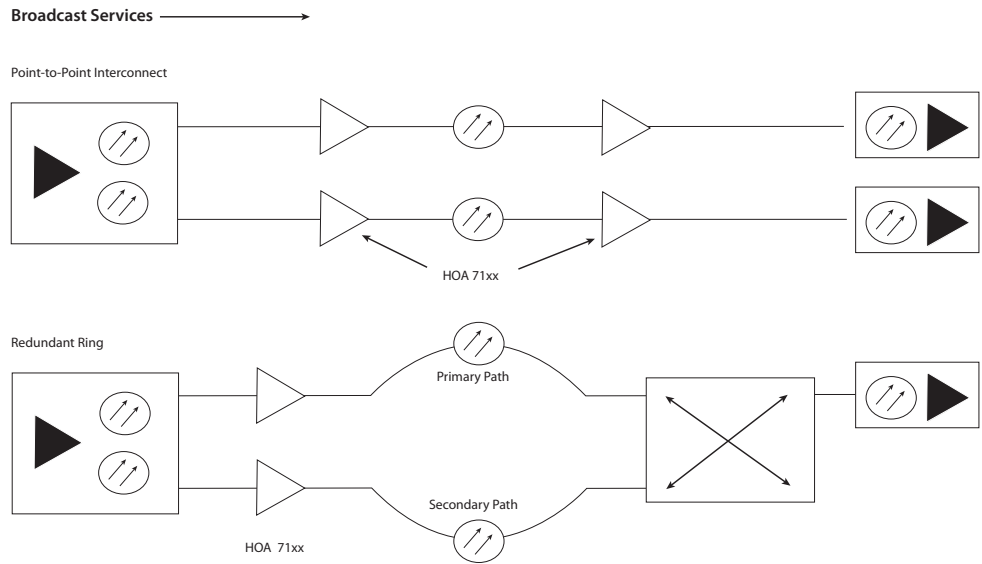

Typical Applications

OPTICAL OUTPUT

Wavelength Range	1540 to 1564 nm
Input Power Range	-5 to +10 dBm

OUTPUT POWER

HOA 7114i	+14 dBm (25 mW)
HOA 7117i	+17 dBm (50 mW)
Optical Power Adjustment Range	3 dB down from maximum
Noise Figure	
HOA 7114i	< 4.7 dB
HOA 7117i	< 4.8 dB
Optical Return Loss	> 40 dB1
Polarization Sensitivity	< 0.5 dB
Laser Shutdown	Interlock on fiber tray
Connector Type	SC/APC or E2000

POWERING

AC Version	110/220 V 50/60 Hz
DC Version	-48 V
Consumption	60 W maximum

USER INTERFACE

Front Panel	Full numeric keypad and multi-line alphanumeric display
Optical Monitor Point	-16 dB relative to optical output, on front panel

NETWORK MANAGEMENT

SNMP Protocol	v1, v2c, v3
HTTP Protocol	HTTP 1.1 (with Web browser-based authentication)

ENVIRONMENTAL

Operating Temperature Range	-4° to +140° F -20° to +60° C
Storage Temperature Range	-40° to +158° F -40° to +70° C
Maximum Relative Humidity	85%, non-condensing

PHYSICAL

Dimensions (W x H x D)	19.0" x 1.7" x 11.0" 48.3 cm x 4.3 cm x 28.0 cm
Weight	15.4 lbs / 7.0 kg

Notes:

1. Amplifier off, output only.